

ML4062-MCB-LPBK

Technical Reference

QSFP-DD MCB
MSA Compliant

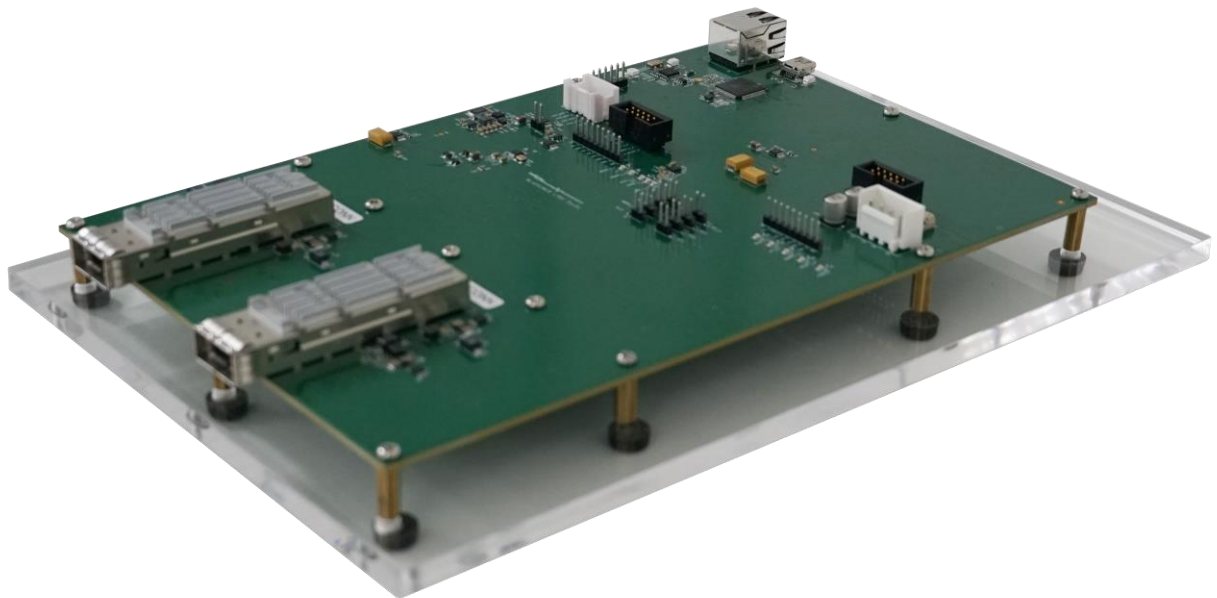

Table of Contents

1	Overview	3
1.1	ML4062-MCB-LPBK QSFP-DD Key Features.....	3
2	ML4062-MCB-LPBK Hardware	3
2.1	Host Power-Up	3
2.2	Module Power-Up.....	3
2.3	Operating Conditions	4
2.4	Default Board Configuration.....	4
2.5	LED Indicators.....	5
2.6	Low Speed Signals.....	6
2.6.1	External HW Control	6
2.6.2	Pin Access	7
3	ML4062-MCB-LPBK Software.....	7
3.1	GUI.....	7
4	Hardware Revision.....	7
5	Firmware Revision	8
6	Bootloader.....	8

Table of Figures

Figure 1: External Power Source	4
Figure 2: Default Board Configuration.....	5
Figure 3: On-board LEDs	5
Figure 4: Hardware Signals	6
Figure 5: Low Speed Signals Schematics	6
Figure 6: Connectors Pin Access	7

1 Overview

The **ML4062-MCB-LPBK** is designed to provide an efficient and easy method of programming and testing 400G QSFP-DD transceivers and active optical cables. It includes a complete user-friendly GUI supporting all features defined by QSFP-DD MSA and simplifying configuration processes to enable intuitive memory map programming and testing.

1.1 ML4062-MCB-LPBK QSFP-DD | Key Features

- Supports two QDD modules
- Tx and Rx lanes of both modules are looped-back on-board
- Matched differential traces length
- High performance signal integrity traces
- I2C master driven from both on-board microcontroller or external pin headers
- On-board pin headers for MSA low speed signals external control
- Internal noise injection option through a programmable switching regulator
- Power margining between 3.1 V and 3.6 V
- On-board LEDs displaying MSA low speed signals states
- Current Sense
- Voltage Sense
- Temperature Sense
- USB interface
- Ethernet interface

2 ML4062-MCB-LPBK Hardware

The subsequent sections cover the essential parts in the hardware, for board operation and testing.

2.1 Host Power-Up

To power up the **ML4062-MCB-LPBK** host, steps are as follow:

- The host TOP is where the cages are mounted
- Apply +5 V DC to connector J5, in the order shown by silkscreen
- Connect the host to the network using the Ethernet plug.

2.2 Module Power-Up

The modules are supplied using one of two powering options:

- From the on-board regulator that uses the main host supply (P5V) as input
- From an external 3.3 V source through connector (U319), by following the steps below:
 - Place a jumper between LDOS_OFF and P5V pins of U319 connector to disable the on-board regulator
 - Apply external 3.3 V at P3VX_HOST pins of U319 connector, shown in the Figure 1.

Each module has its own supply pins, labeled by the silkscreen, as shown below.

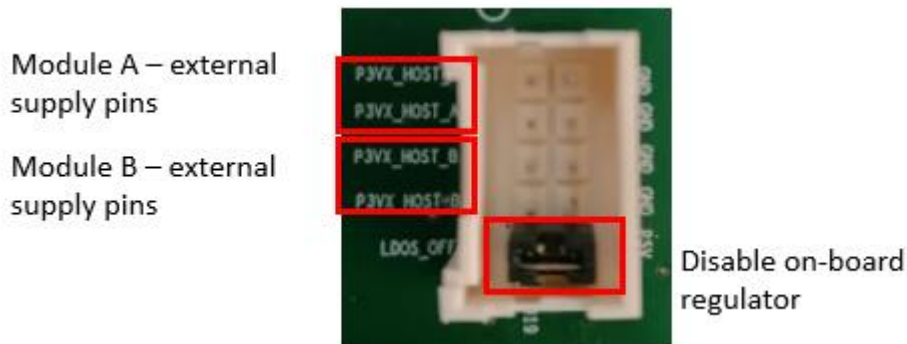

Figure 1: External Power Source

In both cases the +5 V supply through the main power connector must be present to supply the micro and other features.

2.3 Operating Conditions

The input voltage supply must follow the table below.

Parameter	Symbol	Condition	Min	Typical	Max	Unit
+5	P5V	Supply from (J5)	-	5	-	V
+3.3	P3VX_HOST	Supply from (U319) P3VX_HOST	3.0	3.3	3.6	

Table 1: Voltage Operating Conditions

2.4 Default Board Configuration

The default operation of the board consists of the following:

- Module is supplied from on-board regulator:
 - LDOS_OFF pulled to GND
 - POWER_ON/OFF_A/B pulled to GND
- SCL_A/B, SDA_A/B, INT_L_A/B and MODPRS_L_A/B are pulled-up by placing the corresponding jumpers.

The image below shows the default jumpers placement for the low speed signals.

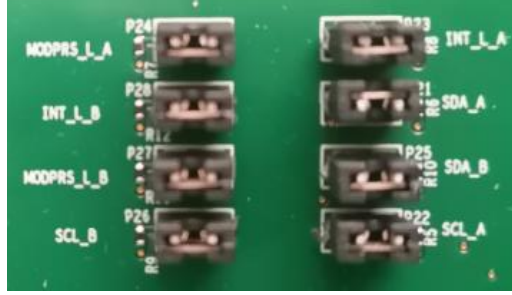

Figure 2: Default Board Configuration

2.5 LED Indicators

The **ML4062-MCB-LPBK** includes on-board LEDs, for quick debugging and monitoring purposes. LEDs are summarized below:

- LED D11 for Ethernet operation.
- LED D3 indicated whether a USB cable is connected or not
- LEDs D2 and D4, colored green and red, respectively, are used for diagnostic purposes:
 - If D2 is on: USB is locked and device is recognized by the USB driver
 - If D4 is on: USB is not connected or USB driver is not found
 - If both are off: board is not powered correctly or firmware is corrupted
 - If both are blinking: the board is in Bootloader mode

Low speed signals monitoring LEDs for both modules are summarized below:

- LED D8/D9: LPMODE_A/_B signal
- LED D19/D24: RESET_L_A/_B signal
- LED D16/D17: INT_L_A/_B signal
- LED D18/D22: MODPRS_L_A/_B
- LED D21/D23: MODSEL_L_A/_B

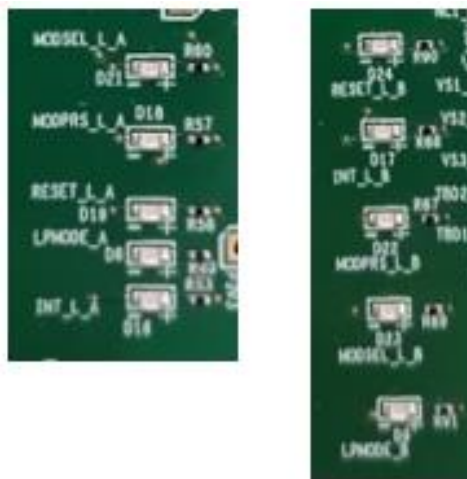

Figure 3: On-board LEDs

2.6 Low Speed Signals

2.6.1 External HW Control

Low Speed Signals are controllable using an external source, this can be done through J7 and J8 pin headers, for modules A and B, respectively. In this case a jumper should be placed on pin header P19 (HW_CTRL) shown in the image below.



Figure 4: Hardware Signals

When a jumper is placed on P19 (HW_CTRL), the control signals can be accessed externally through pin headers shown above. In this case control signals are tri-stated in the microcontroller and controlled externally by the user.

The low speed signals circuit shown below shows the connection of these signals to the microcontroller and QSFP-DD connector.

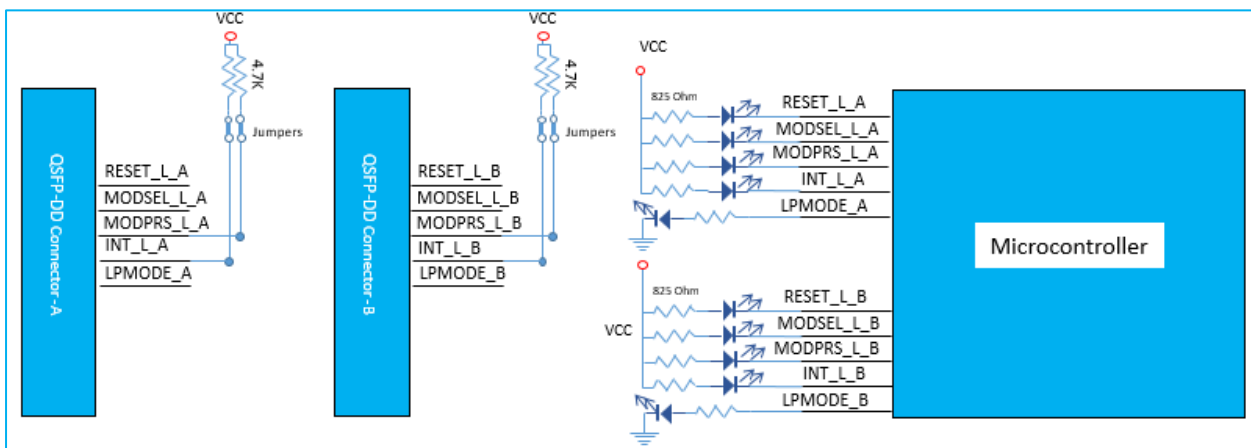

Figure 5: Low Speed Signals Schematics

2.6.2 Pin Access

All QSFP-DD pins are accessible through pin header connectors, including I2C, Control and Status signals.

This can be done through connectors J7, J18, J8 and J19, for modules A and B, as shown in the image below.



Figure 6: Connectors Pin Access

3 ML4062-MCB-LPBK Software

The **ML4062-MCB-LPBK** is accessible and controlled through application software. This software is MSA compliant and provides a user-friendly interface to operate the board and access all its features. The communication between the **ML4062-MCB-LPBK** board and the software is established through Ethernet connection.

3.1 GUI

For GUI installation and operation, refer to the link below. GUI user manual is available for detailed description.

<https://multilaneinc.com/products/ml4062-mcb-lpbk/>

4 Hardware Revision

- **ML4062-MCB-LPBK-RevA1:** Initial Version
- **ML4062-MCB-LPBK-RevB1:**
 - Add EEPROM
 - Fix the value of R54
 - Fix D12 orientation

5 Firmware Revision

- **ML4062MCB-LPBK-RevB1_V1_1**: the latest FW compatible with the ML4062-MCB-LPBK-RevB1 HW

6 Bootloader

Accessing in bootloader mode allows the user to reprogram the microcontroller, this is done as described below:

1. Connect a jumper on P15 (Boot_Run) near the microcontroller.
2. Connect a USB cable between the PC and Board.
3. Power up the board.
4. LEDs (D2, D4) start blinking.
5. Remove jumper.
6. Open the software "Microchip USB HID Bootloader v2.3".
7. Click on "Open Hex File".
8. Choose the target FW to download.
9. Click on "Program/Verify".
10. Once the software finishes programming press on "Reset Device".
11. After reset the Firmware is successfully updated.

Revision History

Revision number	Date	Description
0.1	2/17/2020	<ul style="list-style-type: none">Initial Version
0.2	8/26/2020	<ul style="list-style-type: none">Update FormatUpdate module power-up sectionUpdate default board configuration sectionAdd low speed signals diagramAdd HW and FW revision sections
0.3	10/30/2020	<ul style="list-style-type: none">Update section 3.3
0.31	11/1/2021	<ul style="list-style-type: none">Update Format

North America

48521 Warm Springs Blvd. Suite 310
Fremont, CA 94539
USA
+1 510 573 6388

Worldwide

Houmal Technology Park
Askarieh Main Road
Houmal, Lebanon
+961 81 794 455

Asia

14F-5/ Rm.5, 14F., No 295
Sec.2, Guangfu Rd. East Dist.,
Hsinchu City 300, Taiwan (R.O.C)
+886 3 5744 591