



TRIPOD BARRIER

DESCRIPTION

Tripod Barrier are the ideal solution for single person access and to be used with access control. They are normally installed at monitored area at stadiums, factory, banks or in public transit areas. They can be used in combination with all type of card readers or ticketing machines and are suitable for outside installation

KABEX®

SPECIFICATIONS

Functions	Bi-directions, electronically controllable
Material	SS304 (Optional SS316)
Drive	Hand Operated (Optional Servo Motor)
Mechanism	<ul style="list-style-type: none"> ➤ Electro-mechanical mechanism at the top section of the casework a positive lock action to prevent two passes at one time, a self centering mechanism to ensure complete rotation, a spring damper to ensure smooth operation and anti-backup device to prevent reverse rotation. ➤ Standard Drop Arm feature, Arm will drop automatically during power failure or during emergency, manual reset ➤ Servo motor model, drop arm auto reset when power resume.
Orientation	Pass left or Pass right
Optional	Flash Card Reader Mounting (Surface mounting for customer supplied readers) Status light (Directional Signage Green Arrow/Red Cross) Push Button Control (Simple remote push button console) Digital Usage Counters Mechanical Operation (non-electrical allowing free movement, reverse direction-locked)
Power Supply	230V AC 50/60 Hz
Logic Voltage	24V DC for Controller Board
Delivery Details	Fully assembled , weight: 55 Kg

ORDERING INFORMATION

EXAMPLE : TB-LM304

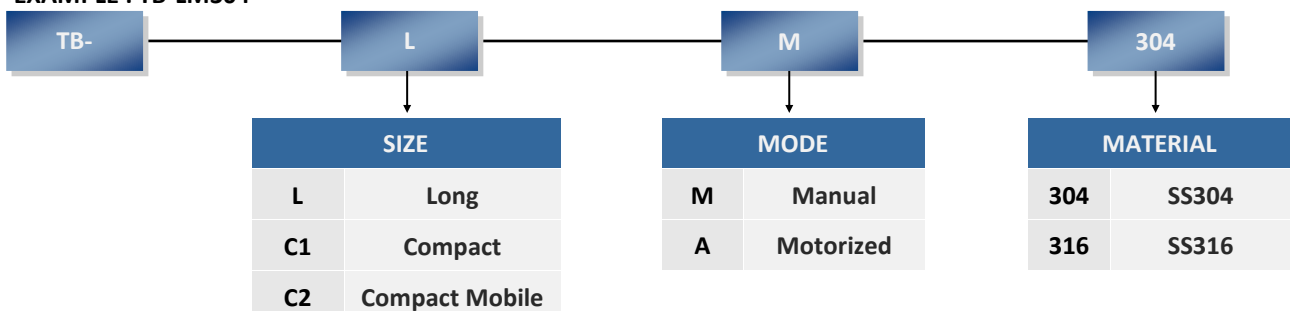

KUMPULAN ABEX SDN BHD

+6(03) 5192 2898

+6(03) 5192 2633

sales@kabex.com.my

www.kabex.com.my

DIMENSION (mm) - STANDARD

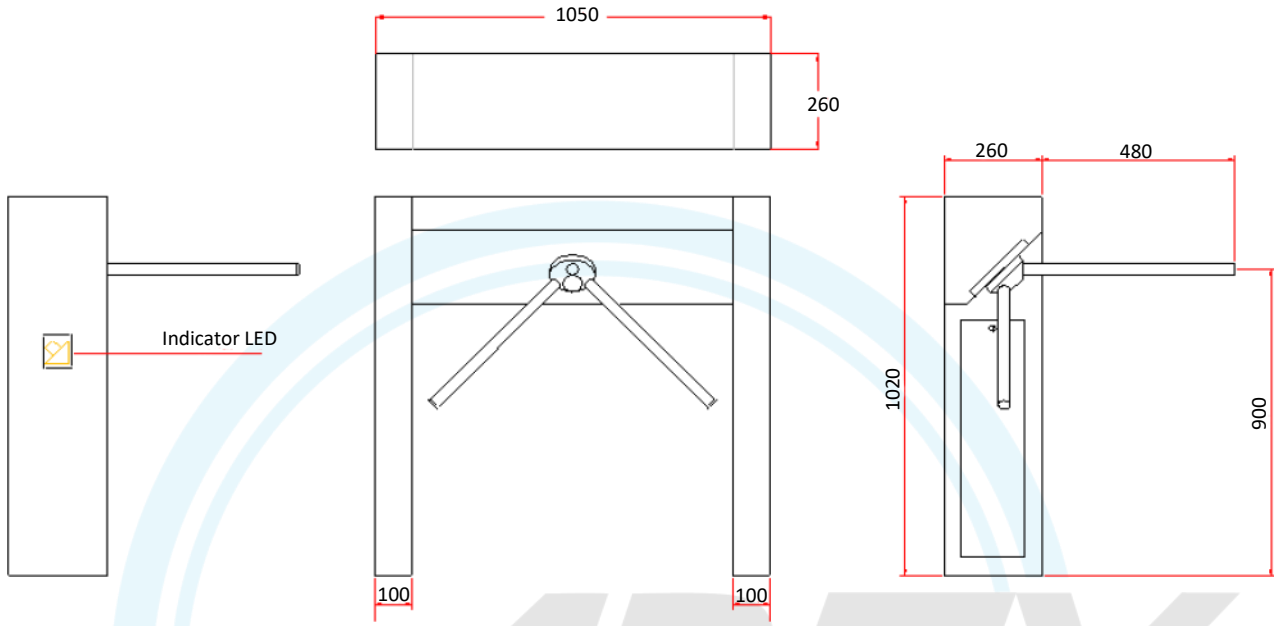

DIMENSION (mm) - COMPACT

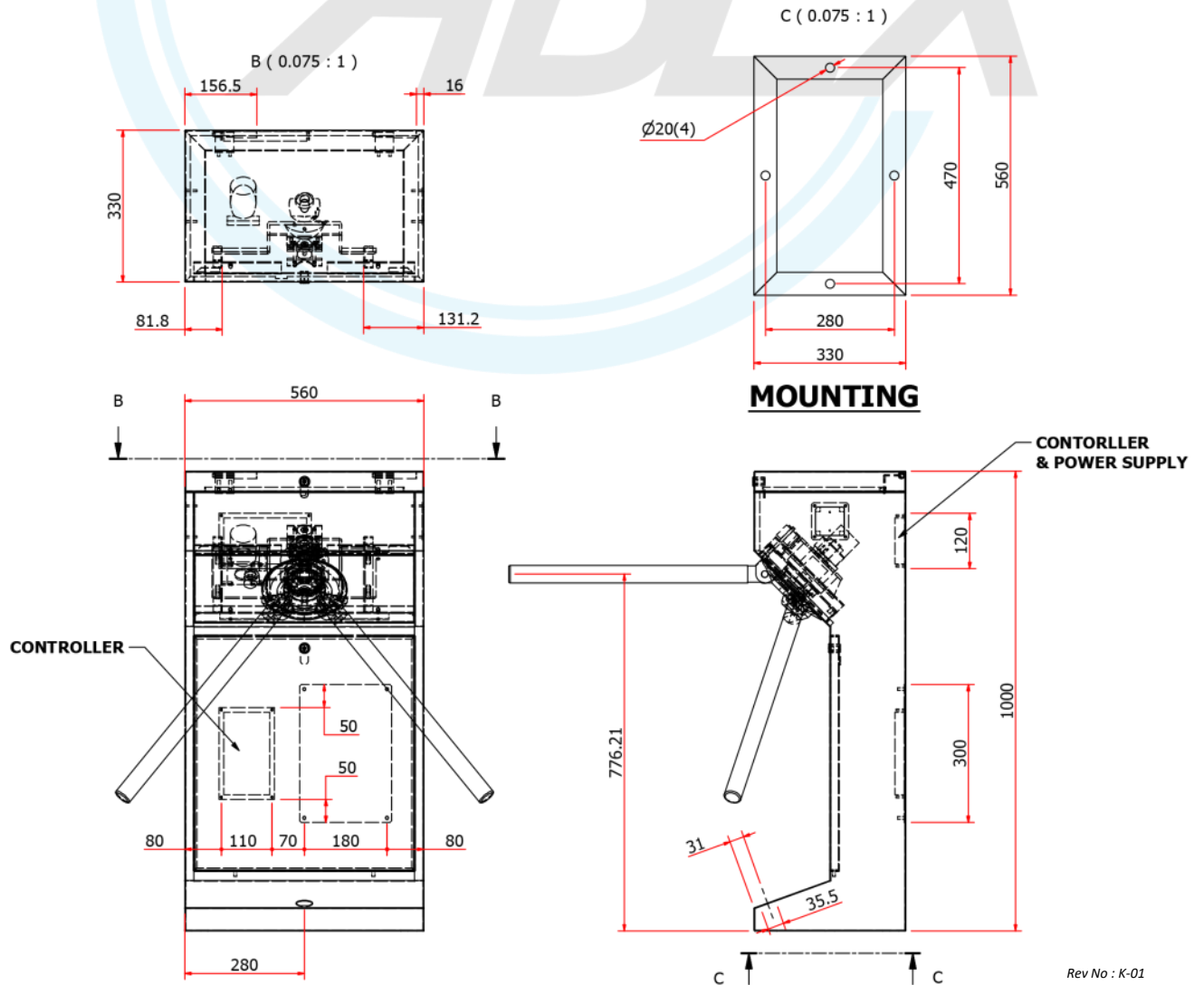

Rev No : K-01
Printed Date : 14/12/2023