

Data Sheet

VIAMI

MAP-220C

Multiple Application Platform, Two-Slot LightDirect Chassis

The compact, 2U, two-slot MAP-220C LightDirect Chassis mainframe is designed for general fiber-optic lab use and smaller optical manufacturer test-station deployments. The MAP-220C is as efficient and cost-effective as fixed-format versions yet maintains the flexibility and modularity so you can build the application you want, when you want.

As part of the larger MAP-200 family, the MAP-220C hosts a specific subset of the broader MAP-200 module array focused on light sources, power meters, switches, and attenuators. These basic foundational modules serve as the key building blocks for most test applications. MAP-220C LightDirect Chassis users can leverage these modules in a compact, benchtop format with a simple, intuitive graphical touch screen.

For larger, more complex deployments, JDSU recommends the MAP-230B (three-slot) and MAP-280 (eight-slot) chassis systems. These chassis support all released MAP-200 modules.

All MAP-200 modules and chassis are completely interoperable with remote interface (GPIB or LXI).



Chassis pictured with mOSW Optical Switch Module installed

Key Features and Benefits

- Compact, two-slot benchtop configuration
- Easily converts to rack-mount configurations in 2 RU high, one-half of a 19-in side-by-side rack format
- LXI-compliant interface with optional GPIB
- Local capacitive touch screen
- Field replaceable controller/power-supply module.

Applications

- General purpose fiber-optic lab use
- Manufacturing test automation
- Light source and optical power meter deployment
- Optical switch and attenuator deployment

Compliance

- General purpose fiber-optic lab use
- Manufacturing test automation
- Light source and optical power meter deployment
- Optical switch and attenuator deployment

Multiple MAP-220C LightDirect Configurations

The MAP-220C has three main configurations that simplify lab use or manufacturing test station integration.

Benchtop

Because each lab bench is unique, the MAP-220C LightDirect Chassis can be flexibly deployed in the space available. Easily stackable and simple, intuitive flip-up feet for easier positioning. The touch screen display's orientation-sensing ability enables positioning the chassis for use vertically or horizontally.



MAP-220C with installed mOSW Optical Switch module

Rack-Mount and Reverse Rack-Mount

The chassis can be ordered in front- or rear-module entry rack-mount configurations. Rack-mount configurations ship in kits containing all necessary mounting hardware, including kits to mount two units side by side. Because each unit is truly a half 19-inch rack wide, two units can be mounted in one standard test equipment cabinet. Conversion kits are available for mounting benchtop configurations.



The MAP-200 LightDirect Module Family

The MAP-220C LightDirect Chassis has been specifically designed to host the MAP-200 LightDirect modules, which are a subset of the easy-to-control, single-functionality MAP-200. Individually or together, these modules form the foundation for most optical test applications.

These modules are the core hosted applications:

Attenuators

The industry specification leader mVOA variable optical attenuator family has been enabling single-level control for receiver and amplifier testing for over 20 years. Available with one, two, or four variable optical attenuators (VOA) per module with or without an internal power meter, the **mVOA-C1** is the industry's most compact modular solution.

Light Source

The 50 GHz tunable **mTLG-C1** distributed feedback (DFB) laser is available in either C or L band, while the mSRC-C1 is a general-purpose light source in these key fixed telecom wavelength bands: 850, 1300, 1310, 1490, 1550, 1625 nm. These sources typically are used to test system load or continuity, measure insertion loss, or for test station calibration.

Power Meters

The **mOPM-C1** optical power meters are available with one, two, or four power heads per module with four unique performance ranges. There are versions available for all applications. Models with 110 dBm dynamic range are complimented by versions that support 26 dBm input power.

Switches

The **mOSW-C1** is the industry's gold standard for loss and repeatability. With over 80 variations available, there is a configuration ideally suited to all applications. Switches range from 1x4 to 1x64 with options for internal power monitoring, direction monitoring, and power trim.

Simple, Intuitive Graphical Controller

The MAP-220C LightDirect Chassis supports a bright capacitive touch screen and intuitive page swipes for easier navigation. Critical data is easy to read, simplifying lab work. A PC is not required for basic operation, freeing up critical space and dramatically reducing implementation costs.

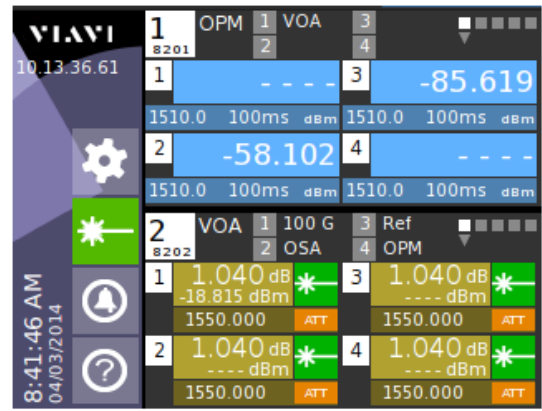
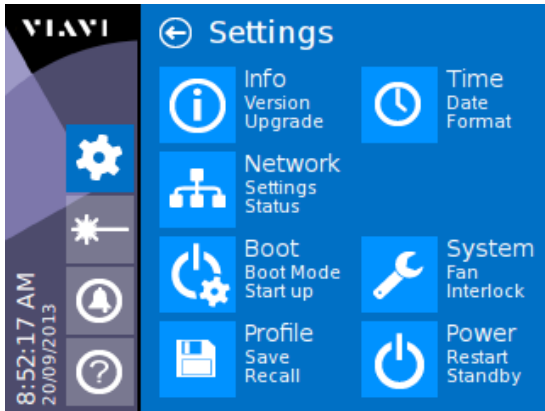

As with all MAP-200 platforms, field maintenance is a priority. The power supply/controller unit is field-replaceable. For integrated test systems, this modularity minimizes maintenance down time.

Control Interfaces

As a full-fledged member of the MAP-200 family, all remote interfaces can interoperate with the three-slot and eight-slot versions. For test integration over Ethernet, full LXI certification ensures a simple, standards-based experience. Leveraging Ethernet enables virtual network computing (VNC) and remote log-in to troubleshoot via remote control.

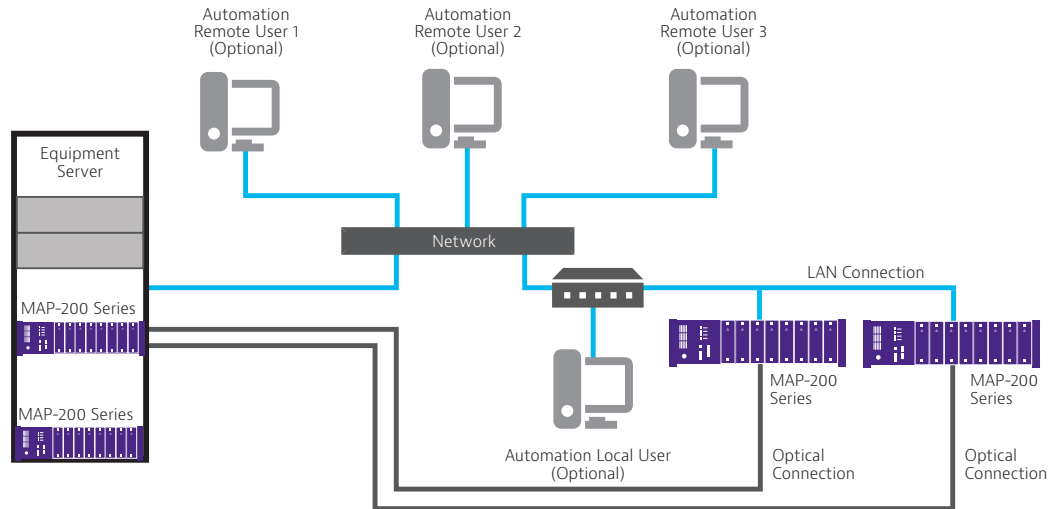

Users who are comfortable with the General Purpose Interface Bus (GPIB) remote interface can order the field-installable option at any time.



Specifications

MAP-220 Parameter	Description
Capacity	2 modules
Controller	
CPU	ARM AM335x
Operating system	Linux
Internal storage	4GB user flash storage
Interfaces	
Remote interface	USB, GPIB (optional), Ethernet 10/100/1000Base-T
USB device capability	Mouse, keyboard, memory stick
Display	Internal display
Ports	
USB host ports	2 rear
LAN	1 rear
GPIB	1 rear (optional)
Automation	
Driver type	IVI-compliant
Driver compatibility	LabVIEW, LabWindows™, Visual C++, Visual Basic
Accessibility	Multi-user sharing support
Electrical and Safety	
Power ¹	100 to 240 V AC, 50/60 Hz, auto-switching (field-replaceable as part of the power supply controller module)
Power consumption	160 VA
Local interlock	Software controlled
Mechanical and Environment²	
Rack-mount kit	Included for MAP-220CX-A or MAP-220CXR-A May be ordered separately to convert a benchtop chassis into a rack-mount chassis.
Dimensions (W x H x D) ³	220 x 88.2 x 387 mm (8.66 x 3.47 x 15.24 in)
Weight	Rack mount: 7 kg (15.43 lb) Benchtop: 8 kg (17.6 lb)

Ordering Information

Description	Part Number
MAP-220	
Benchtop, front fiber exit	MAP-220C-A
Rack-mount, front fiber exit	MAP-220CX-A
Rack-mount, rear fiber exit	MAP-220CXR-A
Power Cord (required)	
United States power cord	CORD-US
European power cord	CORD-EU
United Kingdom power cord	CORD-UK
Japan power cord	CORD-JP
Australian power cord	CORD-AU
Accessories (optional)	
GPIB kit	MAP-200CGPIB-A
Rack-mount conversion kit	MAP-200C01
Benchtop conversion kit	MAP-200C02
Replacement/Spare Parts (optional)	
LightDirect controller	MAP-200CLD-A
MAP-200 blanking plates (kit of 3)	MAP-200A06

1. Mains supply voltage fluctuation shall not exceed 10% of nominal supply voltage.
2. The MAP-200 system has been tested and certified to an altitude of 2,000 meters.
3. Dimensions do not include benchtop hardware or rack-mount ears or connector adapters.
4. The MAP-220C, -220C, and -204C chassis are rated for 50°C; however, some MAP-200 supported modules are only rated to 40°C (as specified in the module's user manual). If using one of these modules, the maximum rating temperature will be 40°C.
5. Short term from 0 to 5°C and 40 to 5°C.



Contact Us **+1 844 GO VIAVI**
(+1 844 468 4284)

To reach the VIAVI office nearest you,
visit viavisolutions.com/contact

© 2021 VIAVI Solutions Inc.
Product specifications and descriptions in this document are subject to change without notice. Patented as described at viavisolutions.com/patents
map220c-ds-lab-nse-ae
30175882 900 0514